



No	Symbol	Cat. No.	K	Total K	Grade	Pos	Remarks
1		8.6.4.1 9.4.1.2 9.1.3.3 9.8.3.1	14 9 6 3	32	.		
2		8.5.6.1 9.4.4.2	10 5	15	.		
3		1.2.8.1 9.1.1.2 9.9.4.2	16 8 11	35	.		
4		5.2.1.4 9.8.1.1 9.4.5.2	22 7 5	34	.		
5		8.4.1.1 9.9.5.3	13 11	24	.		
6		7.4.3.1 9.2.3.4	14 9	23	.		
7		7.2.2.1 9.8.3.2 9.9.3.4	6 7 11	24	.		
8		8.5.7.3 9.4.3.2	10 5	15	.		
9		7.2.3.3 9.1.3.6	6 10	16	.		
10		1.1.1.1 9.2.3.8	2 15	17	.		

Item	K	Grade
Pos.	30	
Harm.	0	
Fig K	235	Total K 265
Penalties		
Too Low		
Too High		
Interruptions		
Insertions		
Trg Violation		
Wing Rocks		
Disqual Fig		
Other(note...)		
Final Freestyle		
Duration	Min	Sec
Judges Details		
Signature		
Name		
Number		

Pilot

AVC



SM Oripää 2023		Form B
Pilot ID	CIVA Advanced Unknown2	
	Flight #	

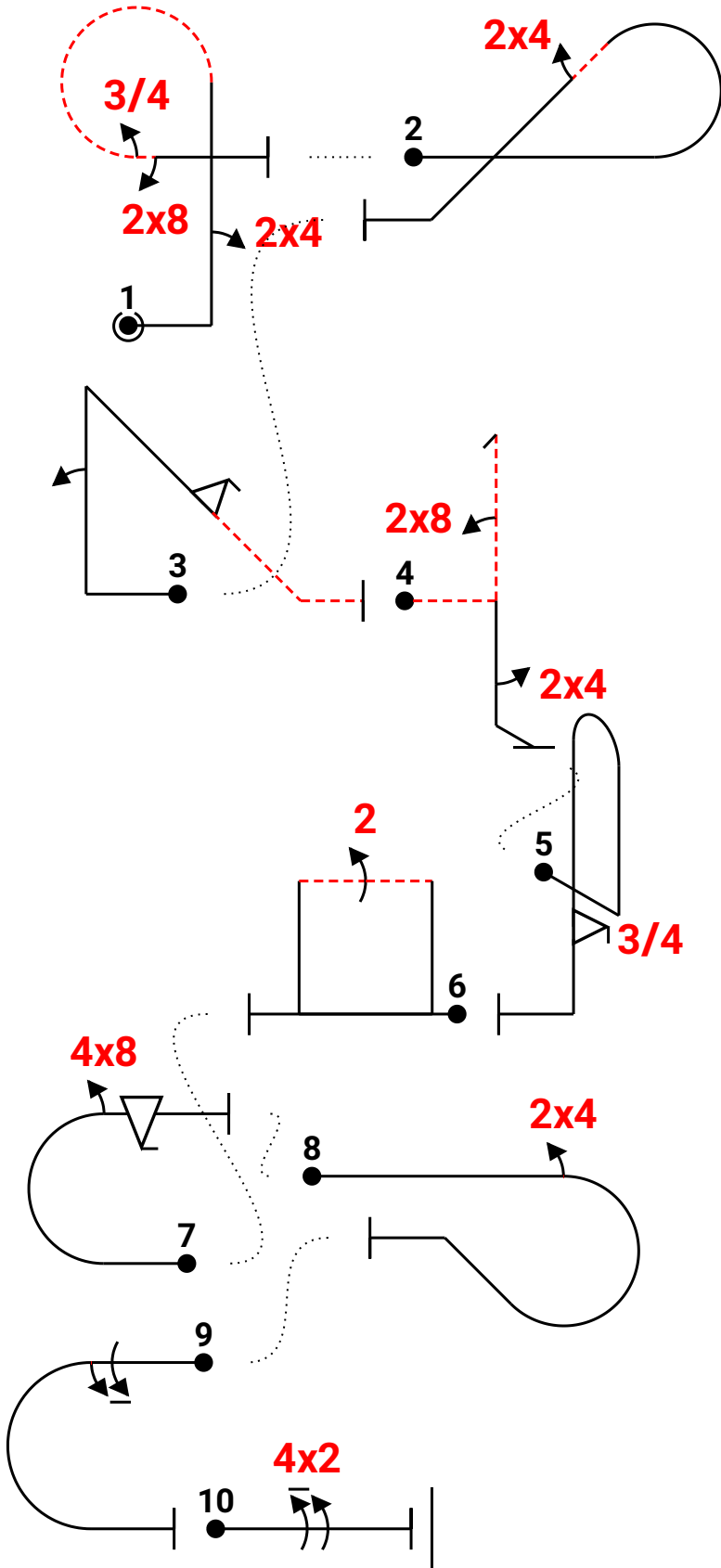
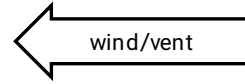

Power			
Fig	Aresti	K	
1	8.6.4.1	14	32
	9.4.1.2	9	
	9.1.3.3	6	
	9.8.3.1	3	
2	8.5.6.1	10	15
	9.4.4.2	5	
3	1.2.8.1	16	35
	9.1.1.2	8	
	9.9.4.2	11	
4	5.2.1.4	22	34
	9.8.1.1	7	
	9.4.5.2	5	
5	8.4.1.1	13	24
	9.9.5.3	11	
6	7.4.3.1	14	23
	9.2.3.4	9	
7	7.2.2.1	6	24
	9.8.3.2	7	
	9.9.3.4	11	
8	8.5.7.3	10	15
	9.4.3.2	5	
9	7.2.3.3	6	16
	9.1.3.6	10	
10	1.1.1.1	2	17
	9.2.3.8	15	
Total K = 235			

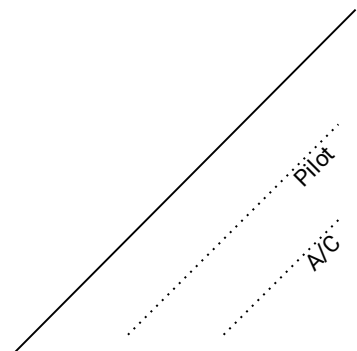

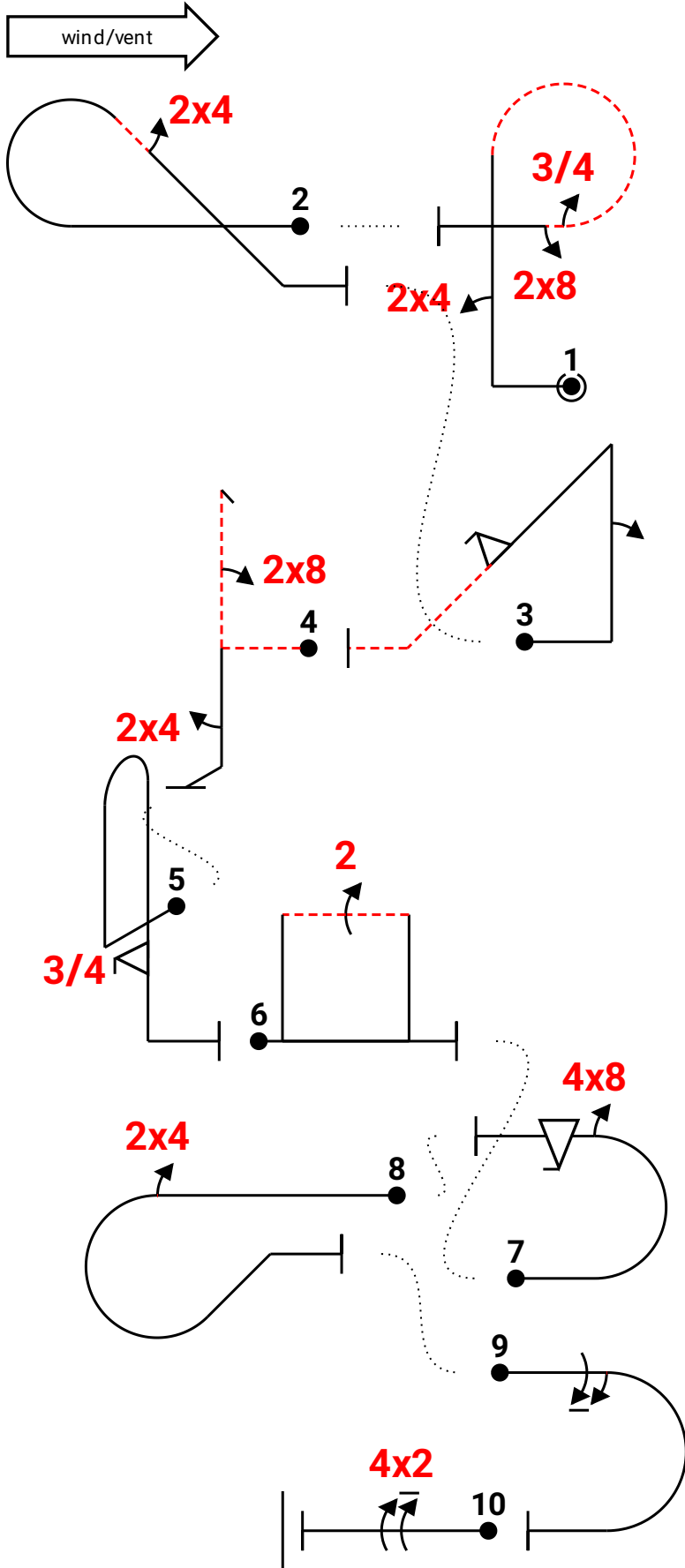

Power			
Fig	Aresti	K	
1	8.6.4.1	14	32
	9.4.1.2	9	
	9.1.3.3	6	
	9.8.3.1	3	
2	8.5.6.1	10	15
	9.4.4.2	5	
3	1.2.8.1	16	35
	9.1.1.2	8	
	9.9.4.2	11	
4	5.2.1.4	22	34
	9.8.1.1	7	
	9.4.5.2	5	
5	8.4.1.1	13	24
	9.9.5.3	11	
6	7.4.3.1	14	23
	9.2.3.4	9	
7	7.2.2.1	6	24
	9.8.3.2	7	
	9.9.3.4	11	
8	8.5.7.3	10	15
	9.4.3.2	5	
9	7.2.3.3	6	16
	9.1.3.6	10	
10	1.1.1.1	2	17
	9.2.3.8	15	
Total K = 235			

Pilot
 A/C

wind/vent ← **R**

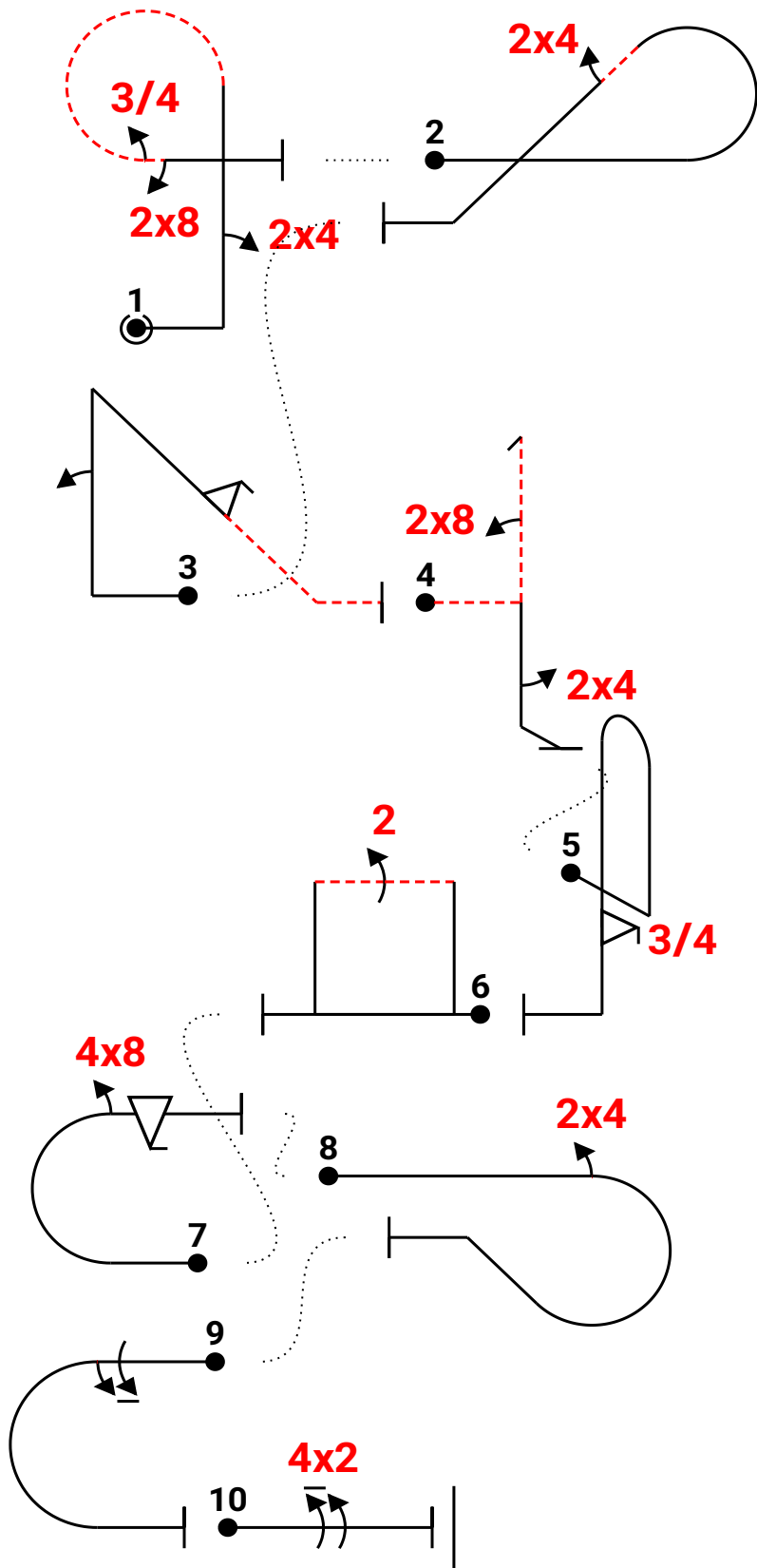

.1% ' ,24rp3,8 (3,0) .2% c,24. (.5,18) 2k2f'' / .8h24+^ (^,3,4) .1% b. '3f+' .2% '''+qo22+' (1,12)
.1% m48,f (0,3) .1% '24ic'''''''''' (.4,6) 6a 42

Fig	Grade	Pos	Remarks
1	.		
2	.		
3	.		
4	.		
5	.		
6	.		
7	.		
8	.		
9	.		
10	.		

Positioning 30

Too Low	<input type="text" value=""/>	Trg Violation	<input type="text" value=""/>
Too High	<input type="text" value=""/>	Wing Rocks	<input type="text" value=""/>
Interruptions	<input type="text" value=""/>	Disqual Fig	<input type="text" value=""/>
Insertions	<input type="text" value=""/>	Other(note...)	<input type="text" value=""/>

Fig 1	K	Fig 2	K	Fig 3	K	Fig 4	K	Fig 5	K	Fig 6	K	Fig 7	K	Fig 8	K	Fig 9	K	Fig 10	K
8.6.4.1	14	8.5.6.1	10	1.2.8.1	16	5.2.1.4	22	8.4.1.1	13	7.4.3.1	14	7.2.2.1	6	8.5.7.3	10	7.2.3.3	6	1.1.1.1	2
9.4.1.2	9	9.4.4.2	5	9.1.1.2	8	9.8.1.1	7	9.9.5.3	11	9.2.3.4	9	9.8.3.2	7	9.4.3.2	5	9.1.3.6	10	9.2.3.8	15
9.1.3.3	6			9.9.4.2	11	9.4.5.2	5					9.9.3.4	11						
9.8.3.1	3																		
	32		15		35		34		24		23		24		15		16		17

Pilot:

A/C:



Figure K
235
Total K
265

Judges Name	
Signature	Number

Flight #

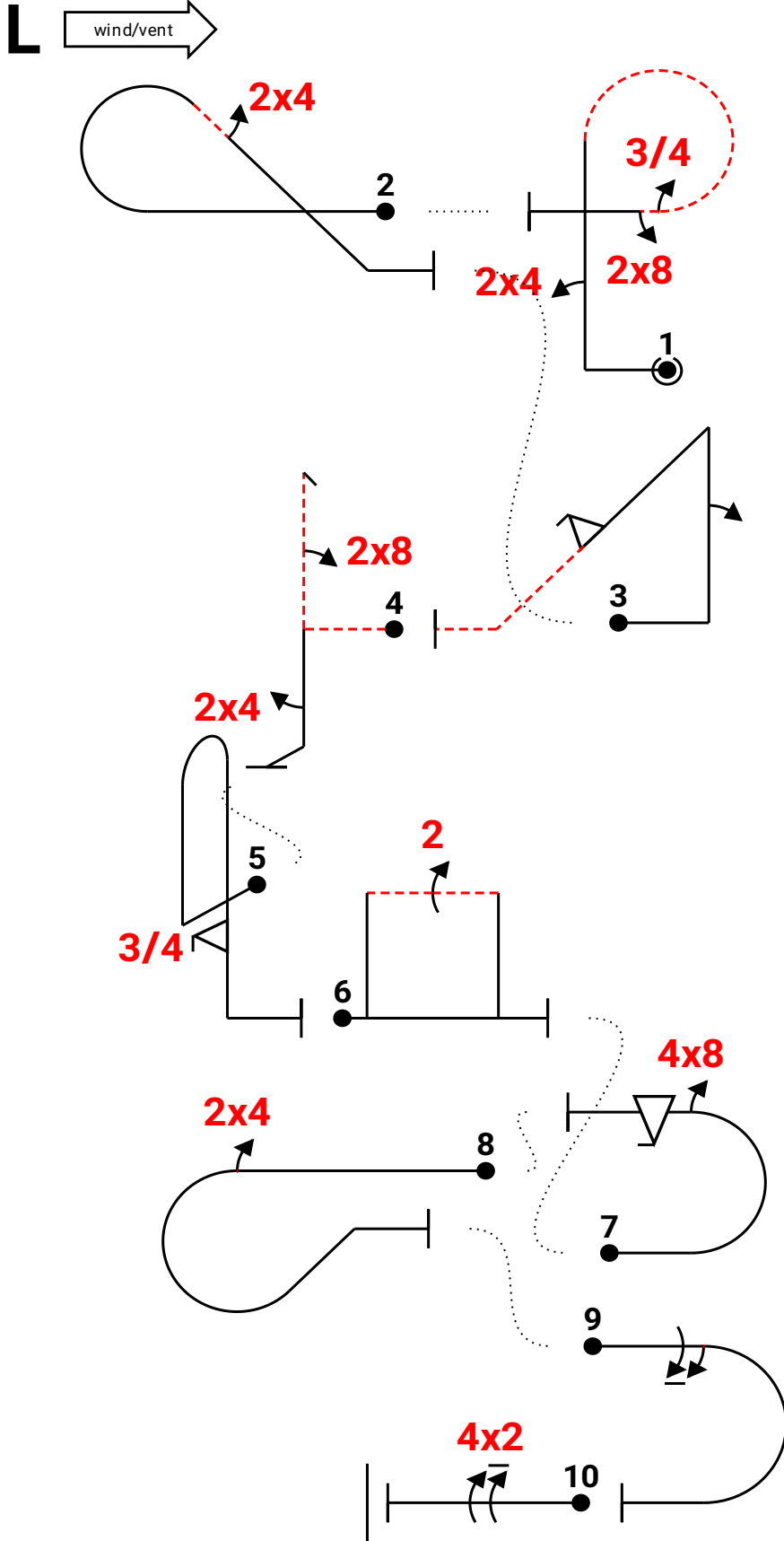

.1% ' ,24rp3,8 (3,0) .2% c,24. (.5,18) 2k2f'' /8h24+^ (.3,4) .1% b.'3f+' .2% '''+qo22+' (1,12)
.1% m48,f (0,3) .1% '24ic'''''''' (.4,6) 6a 42

Fig	Grade	Pos	Remarks
1	.		
2	.		
3	.		
4	.		
5	.		
6	.		
7	.		
8	.		
9	.		
10	.		

Positioning 30

Too Low	<input type="text" value="."/>	Trg Violation	<input type="text" value="."/>
Too High	<input type="text" value="."/>	Wing Rocks	<input type="text" value="."/>
Interruptions	<input type="text" value="."/>	Disqual Fig	<input type="text" value="."/>
Insertions	<input type="text" value="."/>	Other(note...)	<input type="text" value="."/>

Fig 1	K	Fig 2	K	Fig 3	K	Fig 4	K	Fig 5	K	Fig 6	K	Fig 7	K	Fig 8	K	Fig 9	K	Fig 10	K
8.6.4.1	14	8.5.6.1	10	1.2.8.1	16	5.2.1.4	22	8.4.1.1	13	7.4.3.1	14	7.2.2.1	6	8.5.7.3	10	7.2.3.3	6	1.1.1.1	2
9.4.1.2	9	9.4.4.2	5	9.1.1.2	8	9.8.1.1	7	9.9.5.3	11	9.2.3.4	9	9.8.3.2	7	9.4.3.2	5	9.1.3.6	10	9.2.3.8	15
9.1.3.3	6			9.9.4.2	11	9.4.5.2	5					9.9.3.4	11						
9.8.3.1	3																		
	32		15		35		34		24		23		24		15		16		17

Pilot:

A/C:

